



Over 30
activities!

GENERATION TEMPEST ACTIVITY BOOK

You can
colour in the
characters
too!



 **ROYAL
AIR FORCE**



**TEAM
TEMPEST**

MEET YOUR TEAM



Daisy the Designer

It is Daisy's job to design new equipment and test it before it goes into service.

Larry the Logistics Manager

It is Larry's job to make sure that RAF airmen and air women have all the equipment, vehicles, food, fuel and uniform that they need.



Why don't you colour the characters in?



Sally the Security Systems Officer

It is Sally's job to ensure that the military information kept by the RAF on their computers is safe and secure.



Eddie the Engineer

It is Eddie's job to build equipment and machinery and to keep them in good working order.

Anna the Air Traffic Controller

It is Anna's job to use radio and other communication equipment to send clear and correct messages to her team to ensure that military operations run smoothly.

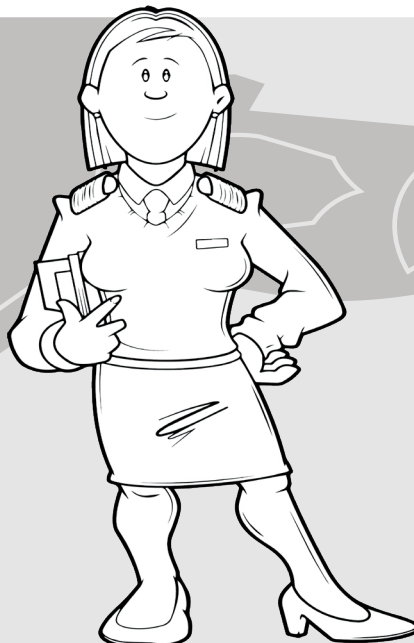

Paul the Pilot

It is Paul's job to fly the aircraft on military missions and to deliver troops and equipment to places.

COUNT THE CLOUDS

Why don't you colour
Eddie and the shapes in?

Eddie the Engineer needs to count the
clouds. Can you write in the box below how
many clouds are in this picture?



EDDIE

HOW MANY
CLOUDS?

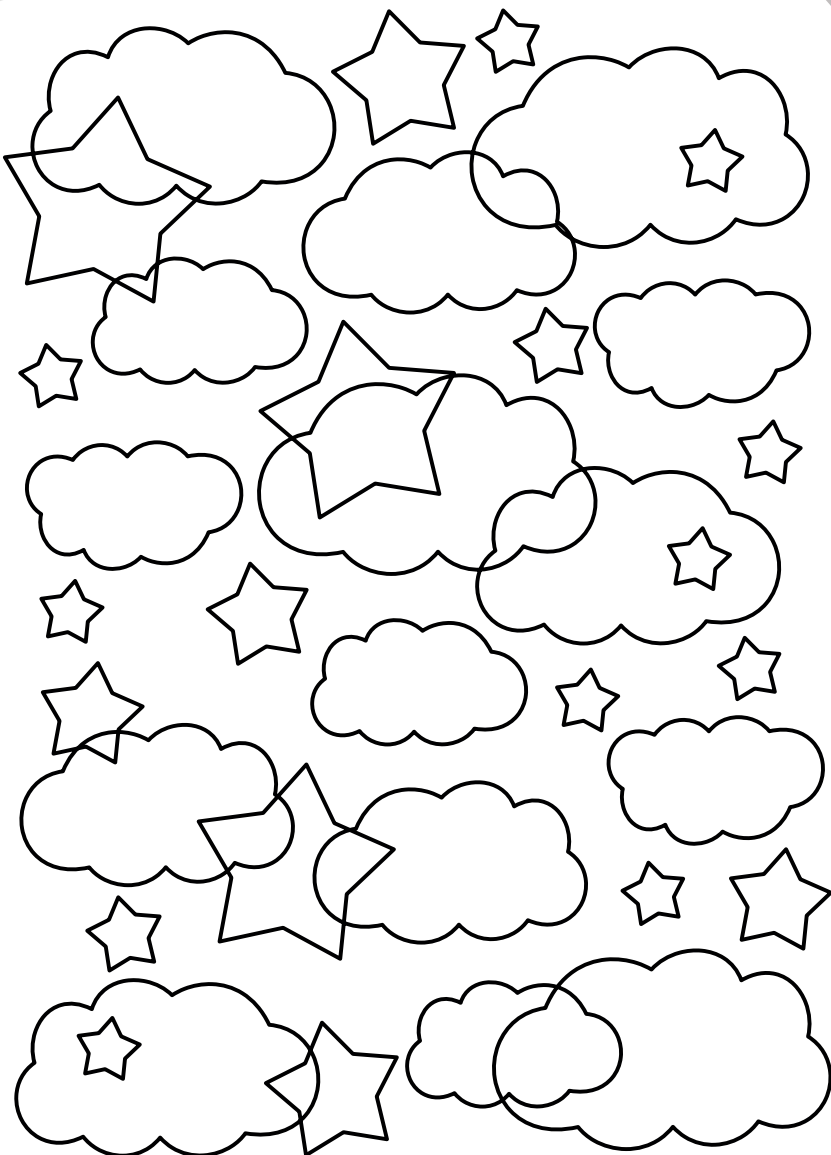

HELP WITH FRACTIONS

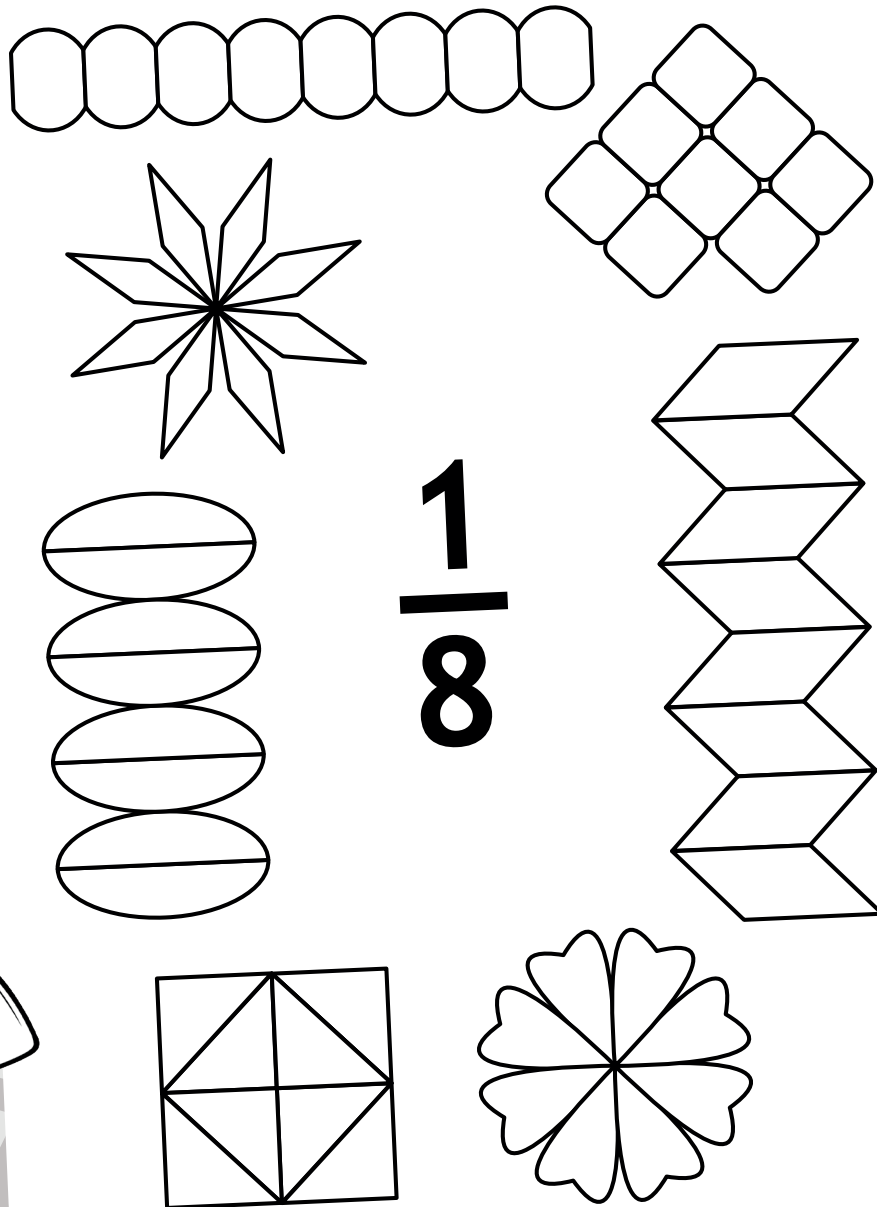

$$\frac{1}{8}$$

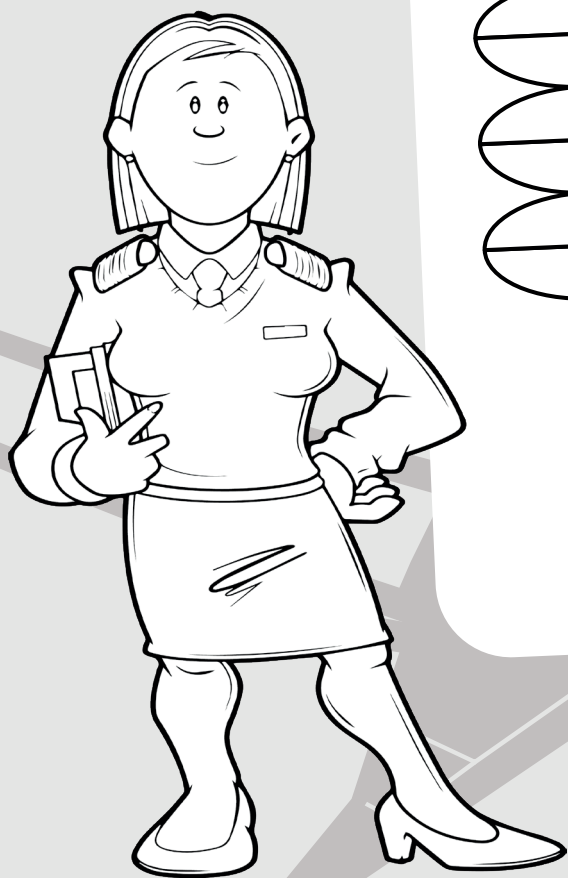

ANNA

Can you help Anna the Air Traffic Controller? She needs you to colour in one eighth ($\frac{1}{8}$) of each of the patterns above.

HEALTHY EATING



PAUL

Paul the Pilot is looking at all the food he ate last week. He would like your help. Can you tick the foods that are healthy, and put a cross next to the ones that are unhealthy?



Milk

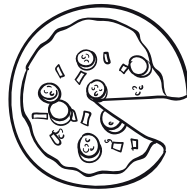

Pizza



Carrot



Banana

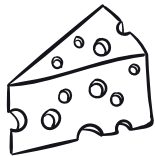

Cheese

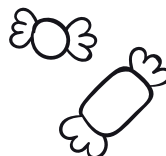

Sweets



Grapes



Cake

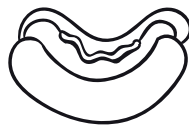

Hot Dog



Chicken



Muffin



Apple



Eggs

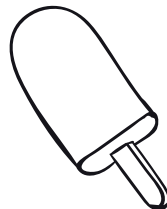

Ice Lolly



Watermelon

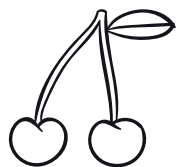

Cherries

FACT

Eating healthy food helps you stay healthy and reduces your risk of many diseases. Fruit, vegetables, low-fat and high-fibre foods are all healthy for us.

AIRCRAFT OF THE FUTURE

Paul the Pilot is looking forward to flying the Tempest aircraft in the future. If you could design an aircraft, what would it look like?

DRAW YOUR DESIGN HERE:



PAUL

COUNTING AIRCRAFT

The year is 2035 and Sally the Security Systems Officer is looking out of the window and can see lots of the new Tempest aircraft.

Can you help her by counting how many there are?

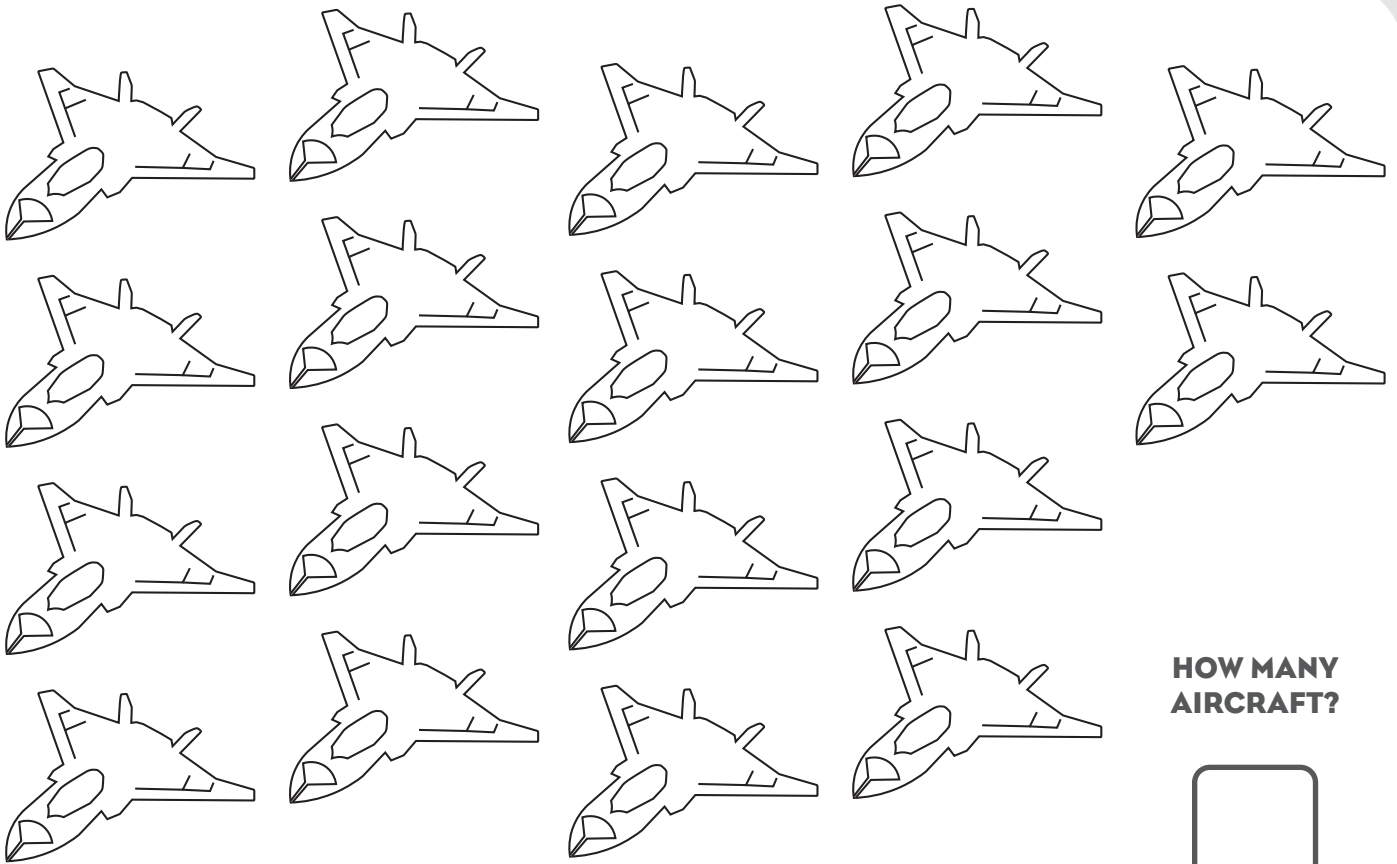

SALLY

Sally remembered that yesterday she saw half as many Tempest aircraft from her window.

HOW MANY AIRCRAFT DID SHE SEE YESTERDAY?

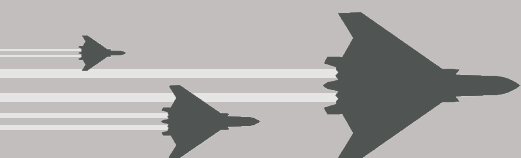

SPOT THE DIFFERENCE

Daisy the Designer is looking at the new designs for the Tempest aircraft. Can you help her to find the differences from the two pictures below?



DAISY

CIRCLE THE DIFFERENCES:

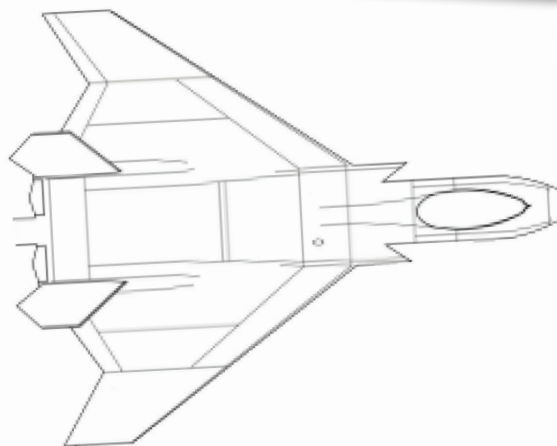
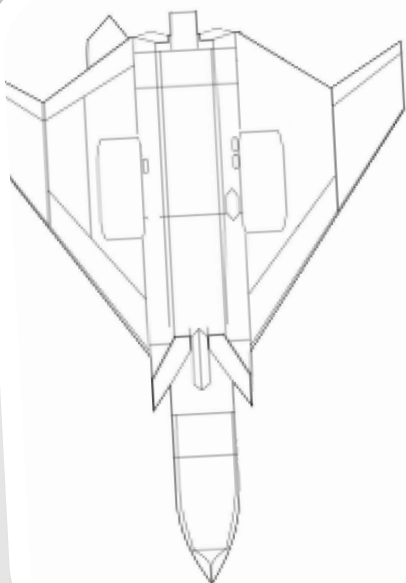
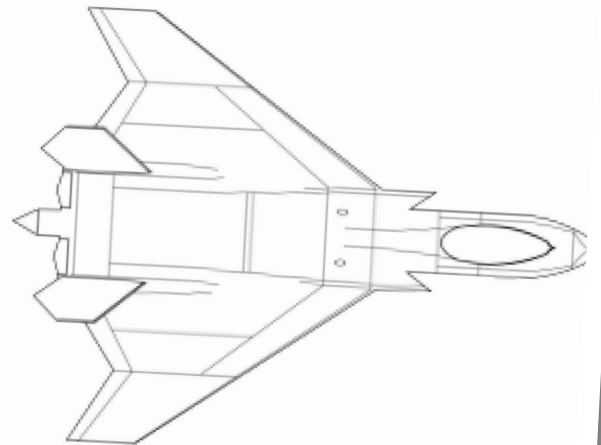
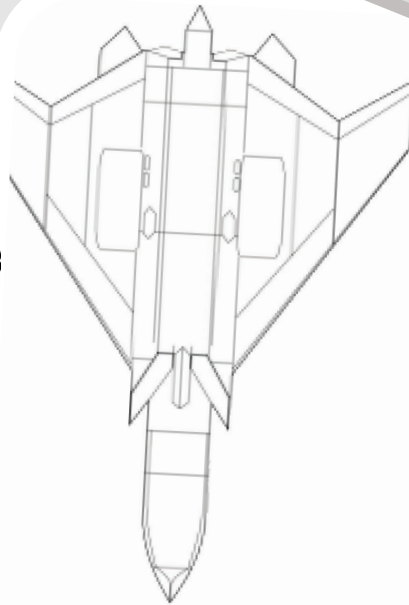

HOW MANY DIFFERENCES?



MATCH THE SHADOW

Larry the Logistics Officer is having an ice-cream during his break from work. It is a really sunny day and his ice-cream is casting a shadow on the ground.

Can you work out the correct shape of the shadow by colouring it in and writing it in the box?

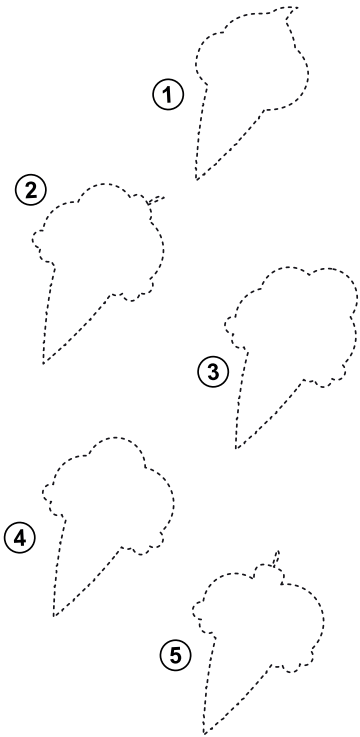

LARRY

**CORRECT
SHADOW
NUMBER IS?**

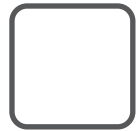

Anna the Air Traffic Controller is having some fruit during her break. Can you work out the correct shape of the shadow of her fruit by colouring it in and writing it in the box?

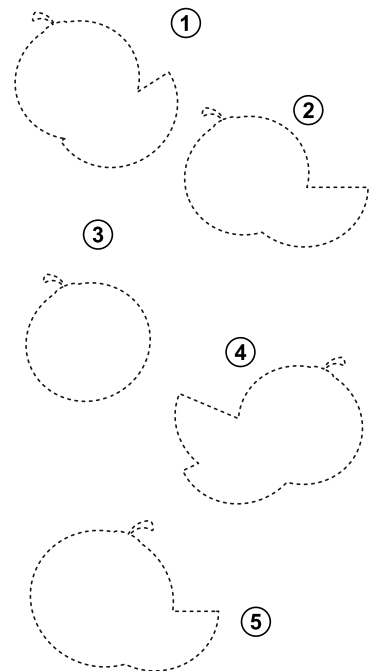
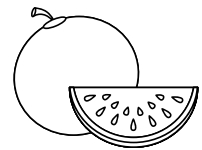

**CORRECT
SHADOW
NUMBER IS?**



ANNA

TANGLED PAIRS

Everyone is working in pairs today.
Can you work out who is working together by tracing the lines?



SALLY



PAUL



EDDIE



DAISY



ANNA



LARRY

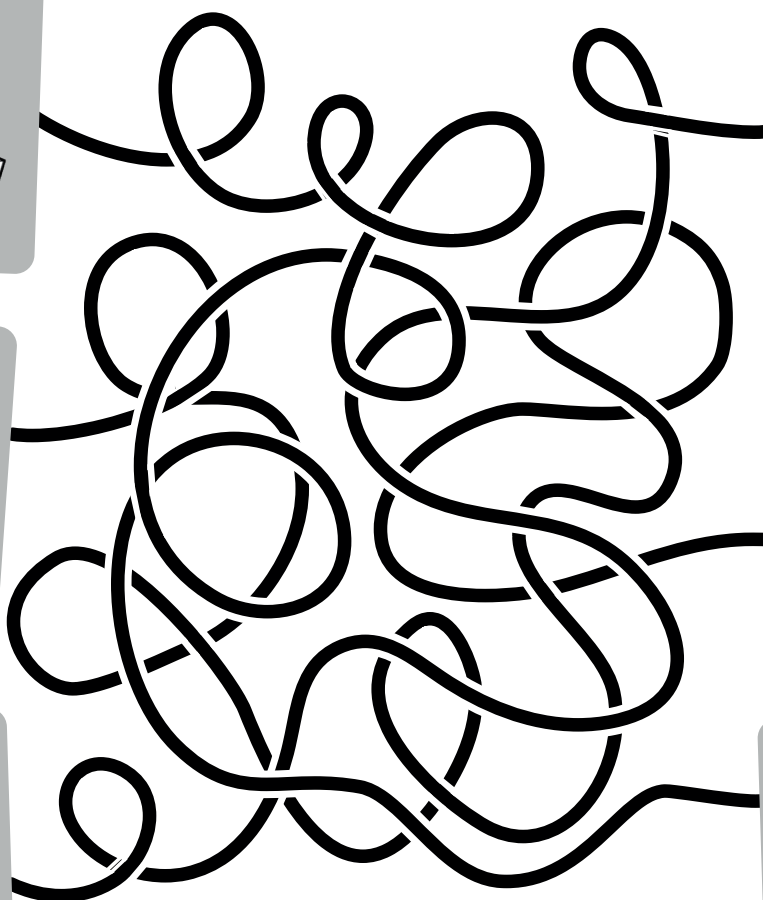

SALLY is working with:

EDDIE is working with:

ANNA is working with:



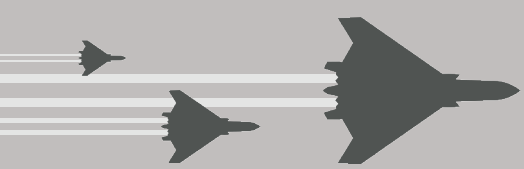
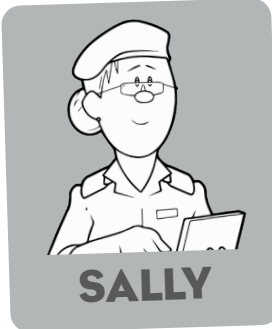

FIND YOUR WAY

Sally the Security Systems Officer needs to collect some equipment from the workshop, but she doesn't know the correct way. Can you help her by drawing a line to the workshop?

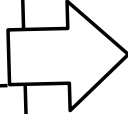

MATHS MAZE

Can you help Eddie the Engineer get out of this maze?
He can only escape through boxes that total 100.

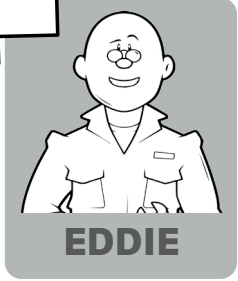
$\begin{array}{r} 32 \\ + 68 \\ \hline \end{array}$	$\begin{array}{r} 15 \\ + 85 \\ \hline \end{array}$	$\begin{array}{r} 73 \\ + 27 \\ \hline \end{array}$	$\begin{array}{r} 22 \\ + 34 \\ \hline \end{array}$	$\begin{array}{r} 43 \\ + 57 \\ \hline \end{array}$	$\begin{array}{r} 35 \\ + 40 \\ \hline \end{array}$	$\begin{array}{r} 11 \\ + 89 \\ \hline \end{array}$	
$\begin{array}{r} 16 \\ + 84 \\ \hline \end{array}$	$\begin{array}{r} 16 \\ + 62 \\ \hline \end{array}$	$\begin{array}{r} 42 \\ + 58 \\ \hline \end{array}$	$\begin{array}{r} 38 \\ + 61 \\ \hline \end{array}$	$\begin{array}{r} 3 \\ + 97 \\ \hline \end{array}$	$\begin{array}{r} 19 \\ + 58 \\ \hline \end{array}$	$\begin{array}{r} 25 \\ + 75 \\ \hline \end{array}$	$\begin{array}{r} 6 \\ + 33 \\ \hline \end{array}$
$\begin{array}{r} 26 \\ + 74 \\ \hline \end{array}$	$\begin{array}{r} 73 \\ + 27 \\ \hline \end{array}$	$\begin{array}{r} 25 \\ + 75 \\ \hline 100 \end{array}$			$\begin{array}{r} 36 \\ + 31 \\ \hline \end{array}$	$\begin{array}{r} 4 \\ + 96 \\ \hline \end{array}$	$\begin{array}{r} 24 \\ + 17 \\ \hline \end{array}$
$\begin{array}{r} 15 \\ + 85 \\ \hline \end{array}$	$\begin{array}{r} 16 \\ + 43 \\ \hline \end{array}$	$\begin{array}{r} 18 \\ + 57 \\ \hline \end{array}$			$\begin{array}{r} 2 \\ + 73 \\ \hline \end{array}$	$\begin{array}{r} 17 \\ + 83 \\ \hline \end{array}$	$\begin{array}{r} 17 \\ + 83 \\ \hline \end{array}$
$\begin{array}{r} 23 \\ + 77 \\ \hline \end{array}$	$\begin{array}{r} 42 \\ + 58 \\ \hline \end{array}$	$\begin{array}{r} 38 \\ + 20 \\ \hline \end{array}$	$\begin{array}{r} 14 \\ + 43 \\ \hline \end{array}$	$\begin{array}{r} 7 \\ + 20 \\ \hline \end{array}$	$\begin{array}{r} 25 \\ + 40 \\ \hline \end{array}$	$\begin{array}{r} 6 \\ + 42 \\ \hline \end{array}$	$\begin{array}{r} 16 \\ + 84 \\ \hline \end{array}$
$\begin{array}{r} 17 \\ + 58 \\ \hline \end{array}$	$\begin{array}{r} 12 \\ + 88 \\ \hline \end{array}$	$\begin{array}{r} 31 \\ + 44 \\ \hline \end{array}$	$\begin{array}{r} 36 \\ + 64 \\ \hline \end{array}$	$\begin{array}{r} 4 \\ + 96 \\ \hline \end{array}$	$\begin{array}{r} 24 \\ + 76 \\ \hline \end{array}$	$\begin{array}{r} 43 \\ + 22 \\ \hline \end{array}$	$\begin{array}{r} 57 \\ + 43 \\ \hline \end{array}$
$\begin{array}{r} 43 \\ + 45 \\ \hline \end{array}$	$\begin{array}{r} 21 \\ + 79 \\ \hline \end{array}$	$\begin{array}{r} 5 \\ + 95 \\ \hline \end{array}$	$\begin{array}{r} 36 \\ + 64 \\ \hline \end{array}$	$\begin{array}{r} 4 \\ + 79 \\ \hline \end{array}$	$\begin{array}{r} 24 \\ + 76 \\ \hline \end{array}$	$\begin{array}{r} 57 \\ + 43 \\ \hline \end{array}$	$\begin{array}{r} 33 \\ + 67 \\ \hline \end{array}$

WORDSEARCH

When designing new aircraft, the RAF needs to think about what shapes to use to help it to fly.

Can you help Daisy find these shapes hidden in the wordsearch?

SQUARE

PENTAGON

CIRCLE

STAR

RECTANGLE

HEXAGON

TRIANGLE

E	A	M	Z	J	K	X	B	L	W	Y	W	N	J	B
L	S	Z	H	Z	F	C	L	D	X	O	O	N	Z	R
G	X	L	S	U	P	W	X	U	C	G	H	M	W	L
N	N	V	U	A	D	M	S	W	A	B	O	E	W	Z
A	E	K	Y	N	N	V	S	X	L	Y	T	V	V	D
I	J	R	R	R	S	Y	E	Q	X	D	B	X	E	X
R	J	N	L	A	Y	H	T	W	U	Q	Z	E	I	N
T	X	A	O	G	L	I	L	E	K	A	P	M	S	S
C	W	E	L	G	N	A	T	C	E	R	R	U	T	U
F	N	H	I	T	A	S	L	U	W	K	N	E	A	G
R	L	B	U	Q	Y	T	W	Y	V	W	Z	I	R	S
A	A	X	F	E	U	A	N	C	I	R	C	L	E	S
K	D	B	Q	U	X	E	C	E	F	L	H	W	R	Z
K	R	K	R	Z	L	U	L	W	P	F	E	N	I	Z
V	Y	C	X	Q	H	D	T	L	Y	F	S	E	F	C



DAISY

SEMAPHORE

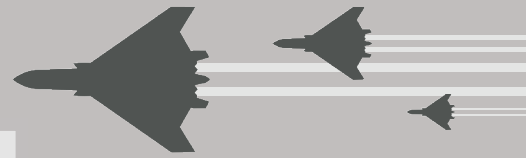

Semaphore is a system of sending messages by holding two flags in certain positions. Each letter of the alphabet is displayed in a different position.

Semaphore is used to send messages when voices cannot be heard. It is used for communicating to pilots before they take off.

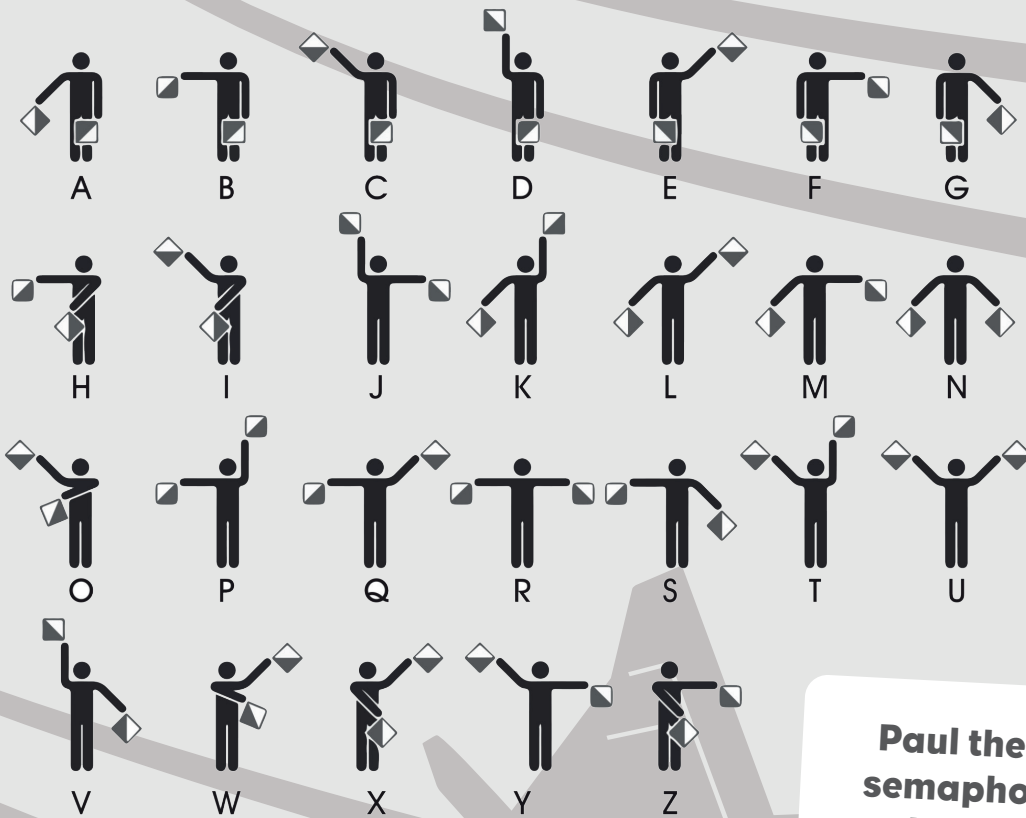

Paul the Pilot has produced a semaphore message for you to work out. Write the correct letter underneath each image to work out the word.

**FILL IN THE
BLANKS**

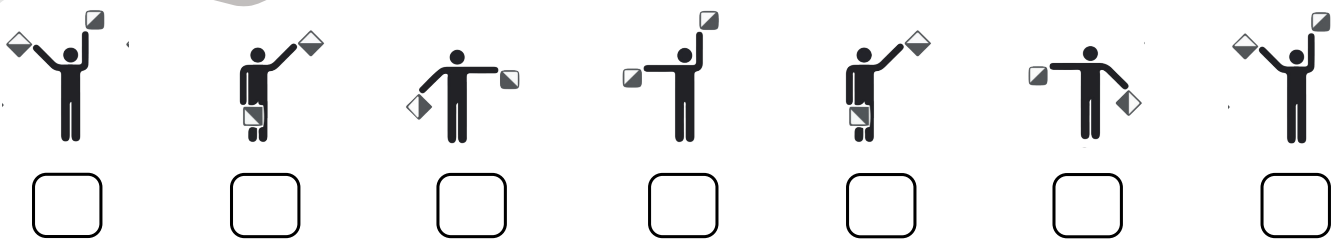

PERFECT PAIRS

Sally the Security Systems Officer is looking at these silhouettes of the new Tempest aircraft.



SALLY

FACT

A silhouette is a dark, solid shape that you see when it has a bright light behind it.

A 	B 	C
D 	E 	F
G 	H 	I

Can you match up the pairs (those that are exactly the same)?

PAIRS WITH <input type="checkbox"/>	PAIRS WITH <input type="checkbox"/>	PAIRS WITH <input type="checkbox"/>	PAIRS WITH <input type="checkbox"/>
PAIRS WITH <input type="checkbox"/>	PAIRS WITH <input type="checkbox"/>	PAIRS WITH <input type="checkbox"/>	PAIRS WITH <input type="checkbox"/>

REACH FOR THE SKY



PAUL

In 2035 Paul the Pilot is flying his Tempest aircraft. Can you work out what altitude he reached today?

DEFINITION

The word **ALTITUDE** means the height reached above sea level or ground level.



At last he reached the highest he could go with another 10,000ft

ft



Within seconds he had gone up another 20,000ft

ft



Then he went up another 5,000ft

ft



At first Paul flew at 10,000ft.

ft

If the new Tempest aircraft could fly twice as high as Paul flew today, how high would this be?

ft



BUILD AN AIRCRAFT

Daisy the Designer has asked if you can join her team and add the labels to this picture of an aircraft.

Can you help her by writing the correct words in the label boxes?



DAISY

FUSELAGE

TAIL FIN

COCKPIT

WING

NOSE

ENGINE

LANDING GEAR

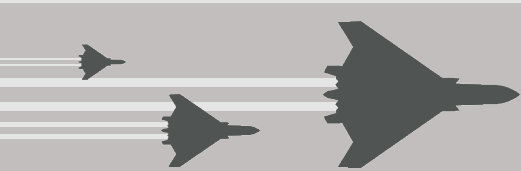
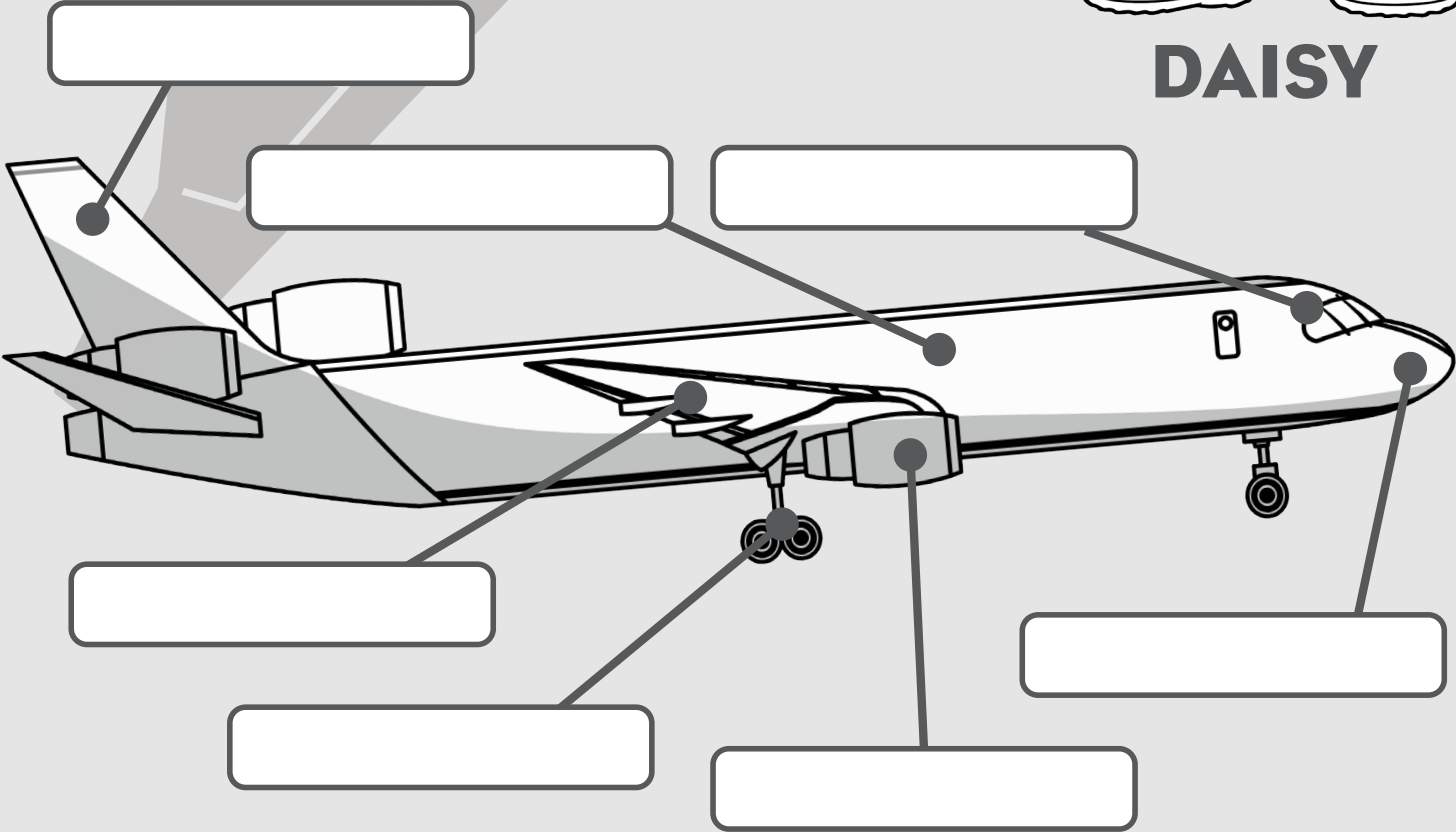

BREAKING CODES

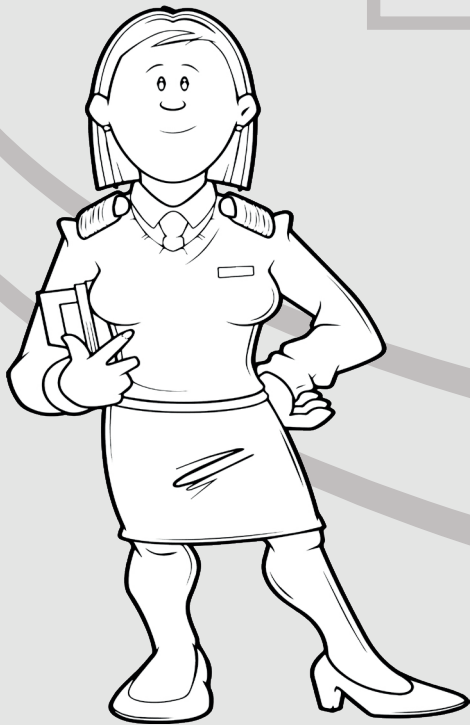

ANNA

Secret codes have been used by the RAF for many years to send secret messages. In some code systems symbols are used in place of letters.

Anna the Air Traffic Controller was wondering if you could work out these words using the codes below?



USE THESE:



There are other types of code systems that are used by the RAF.

These include semaphore and Morse Code.



DEFINITION

MORSE CODE uses a series of 'dots' and 'dashes' for each letter in the alphabet.

FUN WITH SHAPES

Daisy the Designer has created a maths puzzle for you. How many different combinations of these shapes can you make?



For example:



Use this space to help you work out how many combinations there are in total (including the one above).

HOW MANY COMBINATIONS?



DAISY

CROSSWORD PUZZLE

Eddie the Engineer is on his lunch break and he wants to relax by doing a puzzle. Can you help him to complete this crossword before he has to return to work?

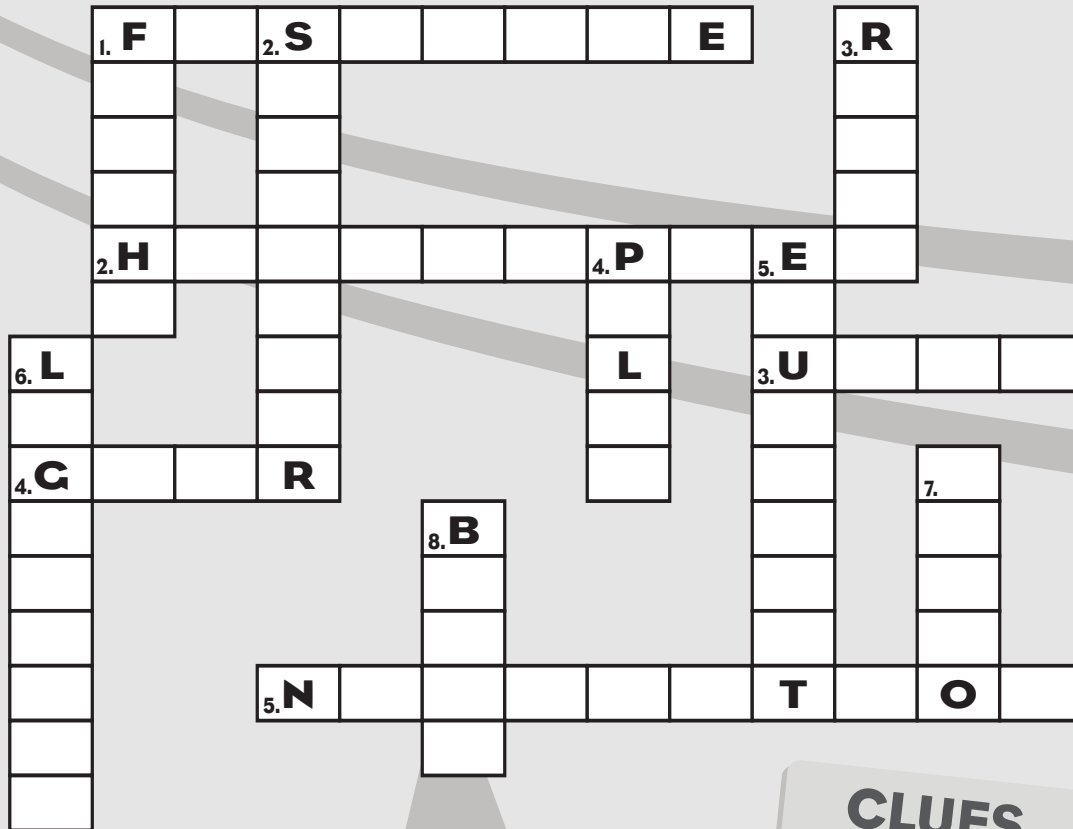

CLUES

Across:

1. The main body of an aircraft.
2. An aircraft that can move horizontally and vertically using rotor blades.
3. Another name for an RAF squadron or group.
4. Kit and equipment used by the RAF.
5. Planning and following a route.

Down:

1. The action of flying through the air.
2. A machine that looks and acts like an aircraft cockpit used for training pilots.
3. A system for detecting aircraft and other objects using radio waves.
4. A person who operates an aircraft.
5. Items used for a particular purpose.
6. The name of the F35, a single-engine aircraft used by the RAF.
7. Communication equipment used to send messages.
8. This is the word used for the letter B in the phonetic alphabet.



EDDIE

GRID REFERENCE GAME



PAUL

Paul the Pilot has asked you to join him in his helicopter as he goes on a rescue mission. He can use this map to locate people trapped by a flood.

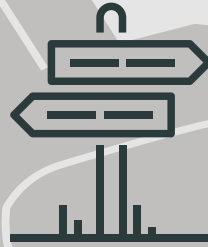

Using the grid reference letters and numbers can you locate each of the people?

EXAMPLE

There is a family sheltering under the tree. Can you write the grid reference so the helicopter can locate them?

Answer is B2. The tree is in row B and in column 2.

	1	2	3	4	5
A			HILLSIDE		
B		TREE			CAVE
C					
D					
E	MOUNTAIN				BUSH

FACT

A grid reference on a map uses vertical and horizontal grid lines to show a location using numbers or letters.

Grid references are sometimes also known as coordinates.

Now, Paul the Pilot needs your help to find the following:

There is a group of people sitting on the hillside.
What is the grid reference?

There is a man at the bottom of the mountain.
What is the grid reference?

There is a class of children and their teacher sheltering in a cave. What is the grid reference?

There is a lady with her dog standing near a bush.
What is the grid reference?

JET ENGINES



EDDIE

Eddie the Engineer is building a jet engine today for the RAF's new Tempest aircraft. He was wondering if you knew how a jet engine works.

FACTS

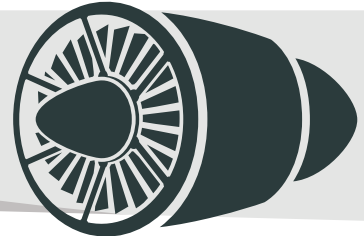

The engine sucks air in at the front with a fan. The gases in the air burn and expand and blast out through the nozzle at the back of the engine. As the jets of gas shoot backwards, the engine and therefore the aircraft are thrust forward.

A nozzle is a cone-shaped or round spout at the end of a pipe or tube used to control a jet of gas or liquid.

Can you count the number of jet engine fans that Eddie has in stock at the moment?

You can colour them in too if you like.

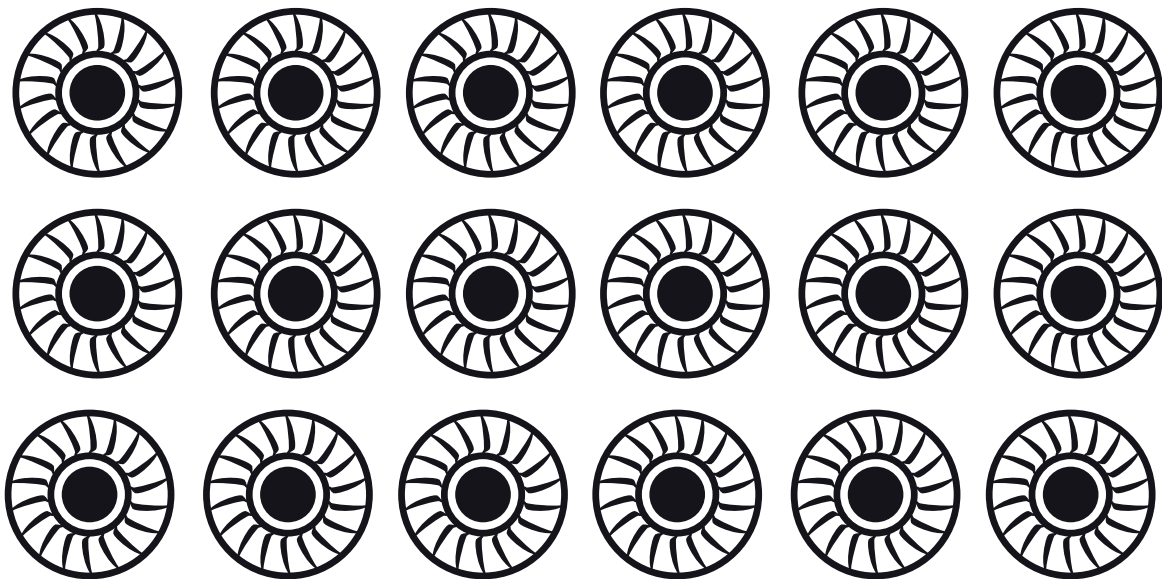

Total number of jet engine fans Eddie has in stock =

JUMBLING GEOMETRY

Eddie the Engineer just loves maths puzzles.

Here is a jumble of triangles and squares. They are all overlapping and making more triangles, squares and rectangles. Can you count how many of each there are?

ADVICE

It's tricky to keep track though. Eddie says to outline each shape as you find it. He uses a different colour for each type of shape.

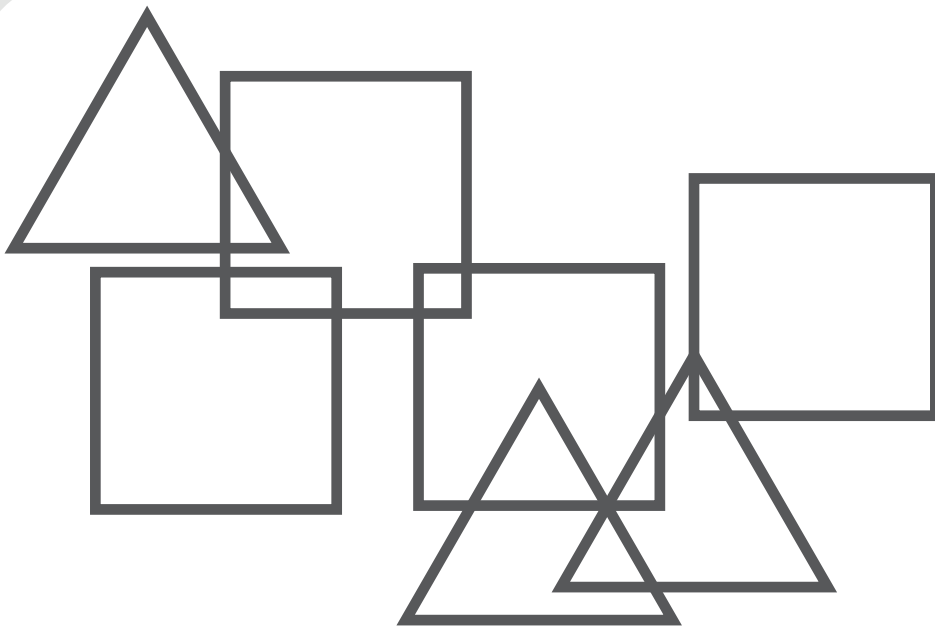

How many triangles did you find?

How many squares did you find?

How many rectangles did you find?

DEFINITION

GEOMETRY is the part of mathematics that studies the size, shapes, positions and dimensions of things. Squares, circles and triangles are some of the simplest shapes in geometry.



EDDIE

JUST THE JOB

There are lots of job roles in the RAF. Larry the Logistics Manager has been given a list of all the jobs that are currently available for trainees.



LARRY

Unfortunately, the list has got jumbled up. Can you help him to match the correct job titles with the correct job description by drawing a line between the two?



LOGISTICS OFFICER



RADIO CONTROLLER

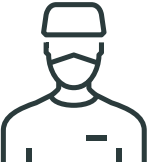

MEDICAL OFFICER

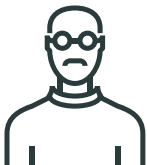

DESIGNER



HELICOPTER PILOT



SYSTEMS SECURITY SPECIALIST

Your job is to make sure everyone stays healthy and any injuries are treated.

Your job is to make sure the troops have what they need when they need it. That includes vehicles, equipment, clothes, fuel and food.

Your job is to design equipment and to test it before it goes into service.

Your job is to ensure the computers and military information are kept secure.

Your job is to use radio and communication equipment to send clear messages to your teams to make sure that military operations run smoothly.

Your job is to fly military helicopters on missions and to deliver troops and equipment to places.

KRISSCROSS

Can you help Larry the Logistics Manager to fit this list of words into the grid below?

DEFINITIONS

An **ALTIMETER** is a device used in an aircraft to measure how high it is from the ground.

The word **MILITARY** means the armed forces of a country.

FLIGHT

WING

AIRFIELD

PARACHUTE

DEFENCE

WEATHER

SECURITY

ALPHA

UNIFORM

SEMAPHORE

HELICOPTER

SPEED

TEAM

ALTIMETER

MAPS

MILITARY

RADIO

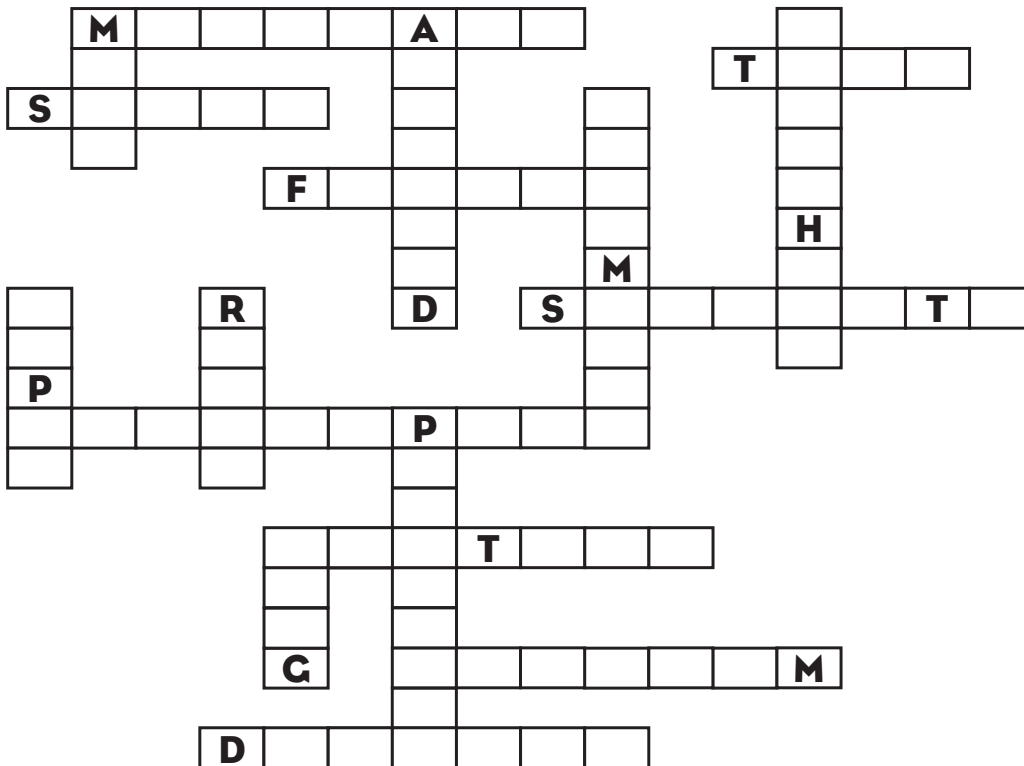

LARRY

LANDING DISTANCE



PAUL

The Queen Elizabeth Aircraft Carrier is 280 metres long. This is about the same length of three football pitches! The RAF can land aircraft on the carrier.

Paul the Pilot has created a maths puzzle for you. He would like you to add up these numbers and tell him if his aircraft would stop safely before reaching the end of the landing deck or if he would run out of space and have to take off again.

LANDING ATTEMPT 1

85

59

57

99

Total:

LANDING ATTEMPT 2

35

88

27

44

Total:

LANDING ATTEMPT 3

65

82

35

97

Total:

FACTS

The Queen Elizabeth Aircraft Carrier is 280 metres long and 70 feet wide.

It can carry 36 F35 Stealth Lightning jets and 4 Merlin helicopters.

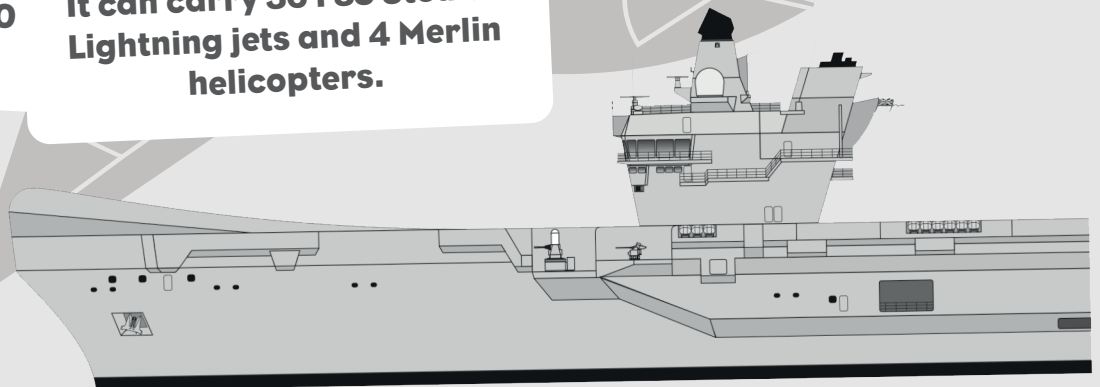

ODDS AND EVENS

There are four aircraft hangars at the RAF airbase where Daisy the Designer works. Each hangar is the same size and when full contains the same number of aircraft.

Some of the aircraft are out on exercise, but can you count those remaining in each hangar?



DAISY

DEFINITION

A HANGAR is a large building used for housing aircraft.

Once you have counted them, can you colour the hangars with the odd number of aircraft in green and the hangars with the even number of aircraft in blue?

Total in this hangar:

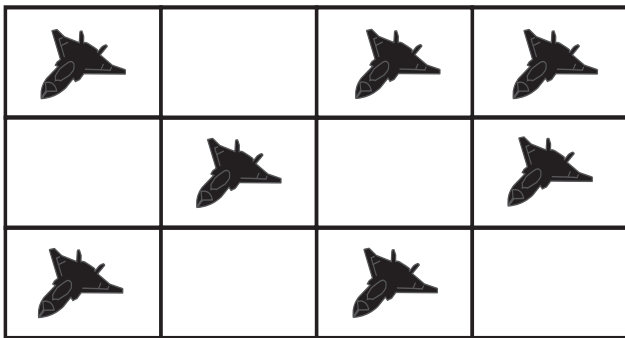

Total in this hangar:

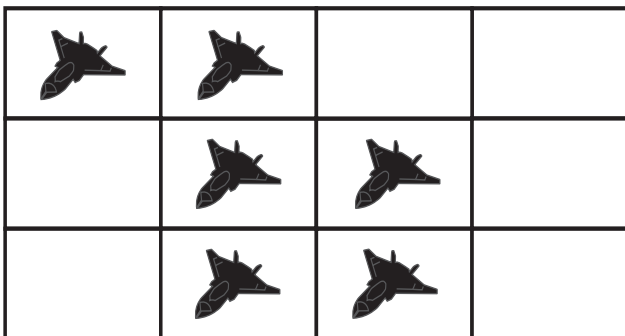
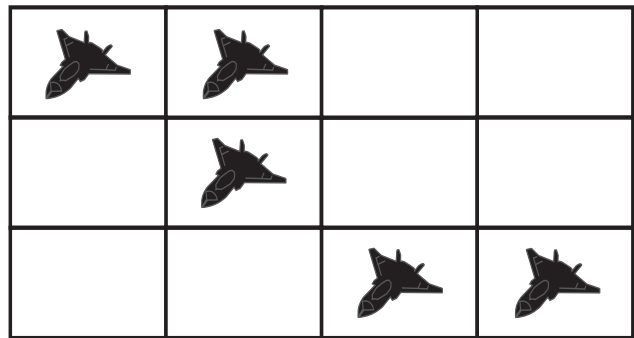

Total in this hangar:

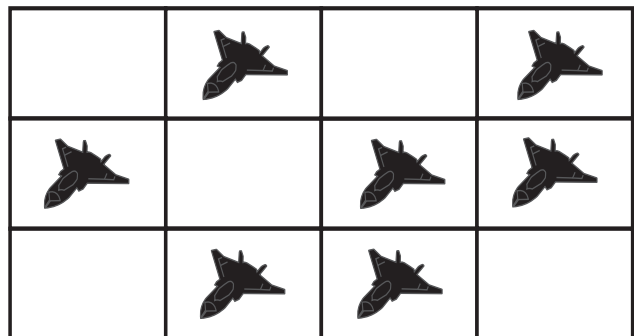

Total in this hangar:

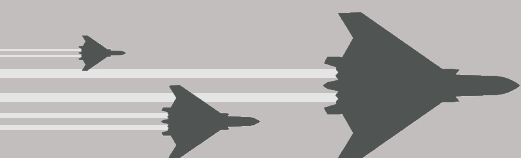

SALLY'S JOB

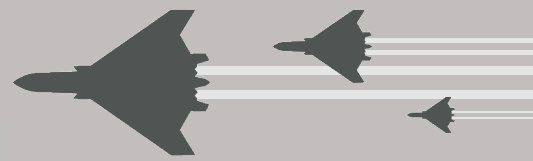

Sally the Security Systems Officer knows how important it is for the RAF to protect their computers and information. This is called Cyber Security.

Some of the words have dropped out of this description of Sally's job. She would like you to read it and help to put the words back in their correct places?



SALLY

COMPLETE THE DESCRIPTION

Sally had a very _____ job to do. She was a Security Systems Officer and she had been working for the RAF in their Cyber Security Department for nearly five _____. Cyber Security is the technology used to protect computers from danger of being attacked. If a computer is _____ the information can be _____ and the computer programmes and networks can be damaged.

It was Sally's job to make sure that all the information the RAF had was kept _____ and hidden. This meant she had to have a password to be able to access the computers. Her password was a secret _____ that nobody but Sally knew. Other people could not see what information was on the computers.

Sally made sure the RAF computer systems had the latest software technology needed to protect them from _____ of attack by hackers and viruses. A hacker is someone who tries to get into a computer without permission. A computer virus is a piece of computer code that can _____ the computer system. Sally was very good at her _____. Every day she checked the systems were safe and every evening she made sure that they were closed down and logged off properly before she went home.

WORD BANK

SAFE

IMPORTANT

JOB

STOLEN

DANGER

WORD

YEARS

DAMAGE

ATTACKED



MATCHING SHADOWS

Eddie the Engineer has a lot of tools. He uses these to build and to repair machinery and equipment for the RAF.
Can you match each shadow to this list of tools?



EDDIE

PAINT BRUSH

TOOLBOX

TAPE MEASURE

SCREWDRIVER

SAW

SCISSORS

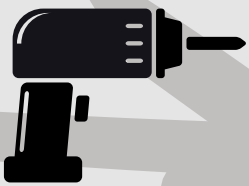

SPANNER

DRILL

PLIERS

FACT

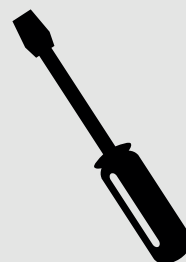

A shadow is the dark shape made when something blocks light. There must be a source of light in order to have shadows. Some sources of light include the sun, a light bulb and a torch. Some things that block light and are great at making shadows are trees, fences, buildings and you! Have a look at your own shadow next time you are outside.

HOW MANY WORDS?

Daisy the Designer thinks it is fun to make smaller words out of the letters of a bigger one. She has made ten little words from each of the big words below.

How many smaller words can you make out of the letters of these long words?



DAISY

CAMOUFLAGE

SURVEILLANCE

DEFINITION

CAMOUFLAGE is the disguising of people and equipment by painting, dressing or covering them to make them blend in with their surroundings. RAF aircraft are painted to look almost invisible in the sky and some animals use camouflage to protect themselves. Can you think of any?

DEFINITION

SURVEILLANCE means keeping a close watch on somebody to see their behaviour.

PHONETIC ALPHABET

The Phonetic Alphabet is a code system used by the military. It is used over the radio or telephone to ensure communication is understood correctly. Air Traffic Control are one of the teams who use this system.

Some letters sound very similar. For example, the sounds of the letters M and N. So, this system helps to prevent a misunderstanding. The radio operator would say Mike for the letter M and November for the letter N.



ANNA

Anna the Air Traffic Controller would like you to write a list of the words from the phonetic alphabet that spell out the following:

A ALFA	B BRAVO	C CHARLIE	D DELTA	E ECHO	F FOXTROT
G GOLF	H HOTEL	I INDIA	J JULIETT	K KILO	L LIMA
M MIKE	N NOVEMBER	O OSCAR	P PAPA	Q QUEBEC	R ROMEO
S SIERRA	T TANGO	U UNIFORM	V VICTOR	W WHISKEY	X X-RAY
Y YANKEE	Z ZULU				

DEFINITION

The word **PHONETIC** means speech sounds. We say the word **PHONETIC** like this 'fonetic'.

COMPASS:

SQUADRON:

RAF:

RADIO:

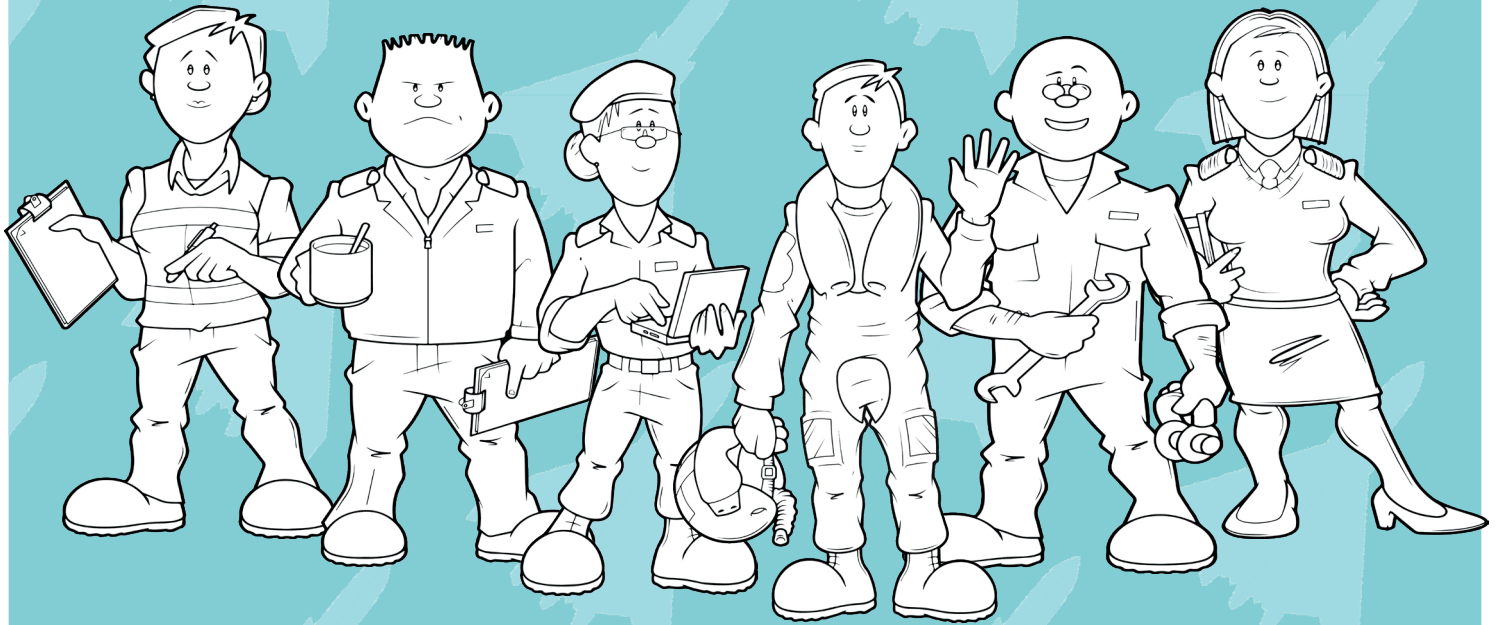

TEAM TEMPEST

 ROYAL
AIR FORCE
Rapid Capabilities
Office

BAE SYSTEMS



 **LEONARDO**

MBDA
MISSILE SYSTEMS

Generation Tempest is a campaign to encourage young people to study and have a career in STEM (Science, Technology, Engineering or Mathematics). Its aim is to create enthusiasm, increase the UK's technical workforce and positively influence the Team Tempest programme.

The new Tempest aircraft will be going into service in 2035 with many years in the air to follow. This means we are working now to inspire people who haven't even been born yet.